

# Ersatzteilliste

## Spare Parts List

4/02



**EM-3310** 2002 →

**EM-3713** 2002 →

**EM-4316 S** 2002 →

**EM-4816** 2002 →



**PM-43** 2002 →

**PM-48** 2002 →

**PM-48 S** 2002 →

---

# DOLMAR

995 700 116 (D, GB)

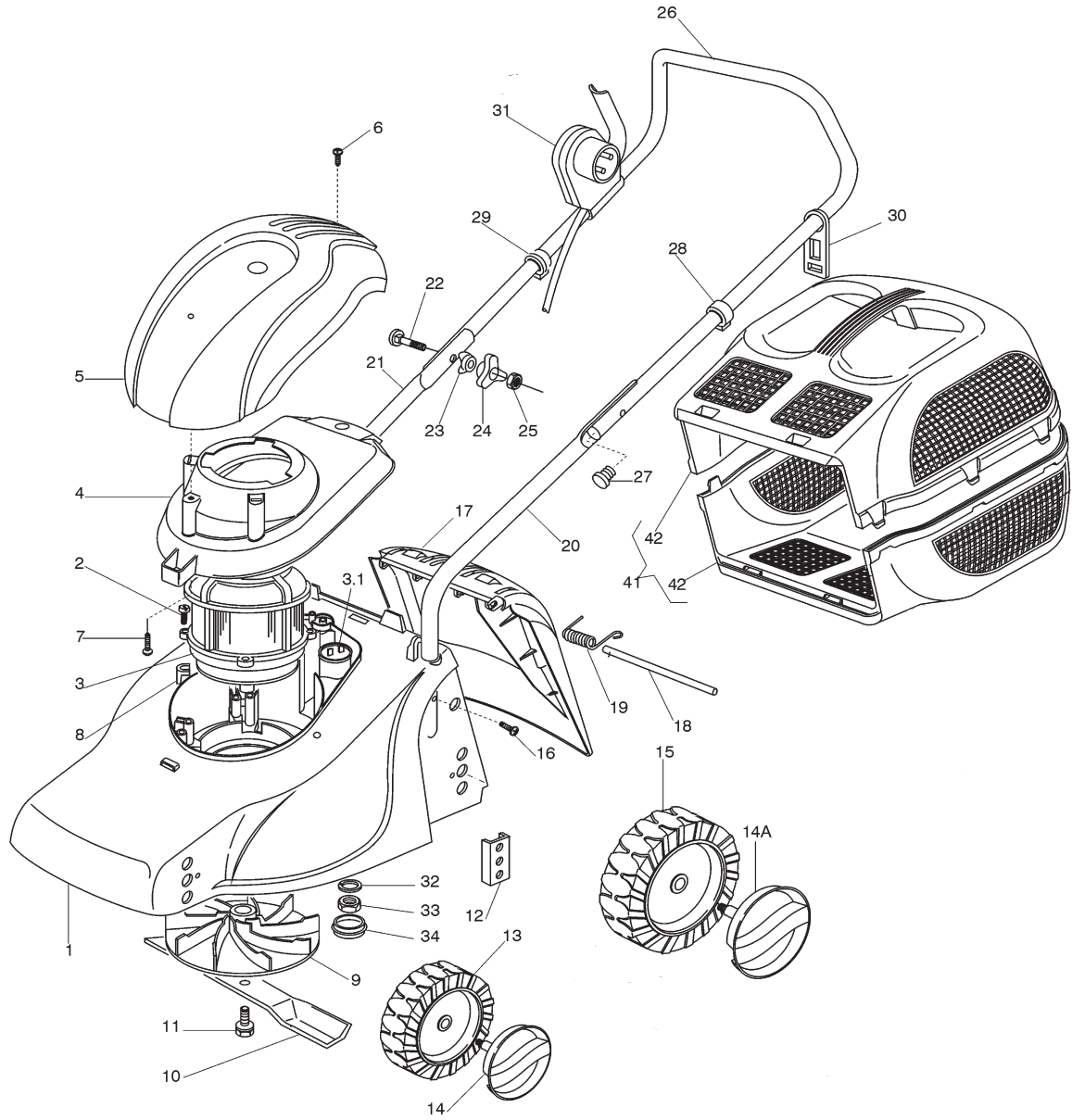

**1****EM-3310****DOLMAR**

Pos.	EM-3310	Teil-Nr. PartNo.	Hinweise Notes	Bezeichnung	Spezifikation Specification	Description
1	1	664 002 366		GEHÄUSE ROT		DECK RED
2	4	664 735 410		SCHRAUBE		SCREW
3	1	664 563 064		MOTOR ATB	1000W (230V)	MOTOR ATB
3.1	1	664 222 036		KONDENSATOR	12 µF	CONDENSER
4	1	664 055 050		HALTER, HAUBE		SUPPORT, COVER
5	1	664 055 049		HAUBE		COVER
6	1	664 728 680		SCHRAUBE		SCREW
7	1	664 728 450		SCHRAUBE		SCREW
8	4	664 167 700		DISTANZRING		SPACER
9	1	664 465 602		MESSERHALTER		HUB
10	1	664 004 115		MESSER STANDARD	33 CM	STANDARD BLADE
11	1	664 004 352		MESSERSCHRAUBE		SCREW
12	4	664 785 087		HÖHENVERSTELLUNG		SUPPORT, WHEELS
13	2	664 686 083		RAD VORNE	Ø 130	WHEEL
14	2	664 004 322		RADKAPPE VORN ROT		HUB CAP RED
14A	2	664 004 323		RADKAPPE HINTEN ROT		HUB CAP RED
15	2	664 686 085		RAD HINTEN	Ø 160	WHEEL
16	2	664 728 450		SCHRAUBE		SCREW
17	1	664 600 055		PRALLBLECH		STONE-GUARD
18	1	664 512 530		BOLZEN		PIN
19	1	664 450 250		FEDER		SPRING
20	1	664 006 940		HOLM, LINKS UNTERTEIL		HANDLE, L LOWER PART
21	1	664 006 939		HOLM, RECHTS UNTERTEIL		HANDLE, R LOWER PART
22	2	664 819 120		SCHRAUBE		SCREW
23	2	664 680 006		SCHEIBE		WASHER
24	2	664 399 900		GRIFF		KNOB
25	2	664 293 200		MUTTER		NUT
26	1	664 006 941		HOLM, OBERTEIL		HANDLE, UPPER PART
27	2	664 566 112		GUMMISTOPFEN		CAP
28	1	664 192 151		KABELBEFESTIGUNG		FAIRLEAD
29	1	664 192 000		BOWDENZUGHALTER		ANCHOR CLAMP
30	1	664 195 101		KABELBEFESTIGUNG		FAIRLEAD
31	1	664 710 611		TOT MANNSCHALTER	6,5A	DEAD HAND SWITCH
32	1	664 540 260		FEDERING		GROWER
33	1	664 293 200		MUTTER		NUT
34	1	664 110 275		GUMMISTOPFEN		CAP
41	1	664 350 000		KORB, KOMPLETT		GRASSCATCHER, COMPLETE
42	2	664 486 048		KORB, OBER/UNTERTEIL		GRASS-BOX, UPPER/LOWER PART
•	1	664 008 592		SATZ, SCHRAUBEN ZUR BEFESTIGUNG VON OBERHOLM UND UNTERHOLM		OUTFIT, SCREWS

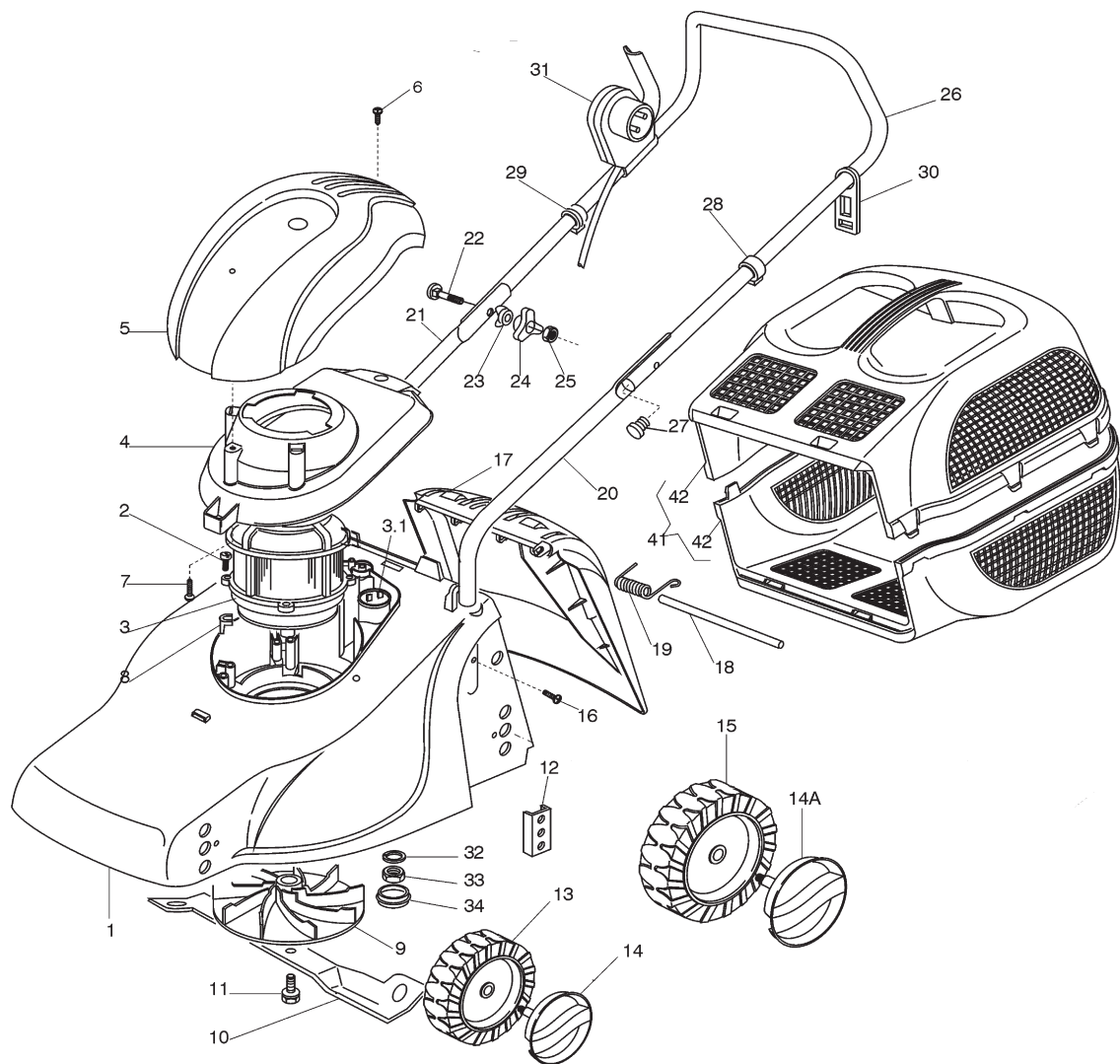

**2****EM-3713****DOLMAR**

Pos.	EM-3713	Teil-Nr. PartNo.	Hinweise Notes	Bezeichnung	Spezifikation Specification	Description
1	1	664 002 367		GEHÄUSE ROT		DECK RED
2	4	664 735 410		SCHRAUBE		SCREW
3	1	664 563 065		MOTOR HLT	1300W (230V)	MOTOR HLT
3.1	1	664 222 036		KONDENSATOR	12 µF	CONDENSER
4	1	664 055 050		HALTER, HAUBE		SUPPORT, COVER
5	1	664 055 049		HAUBE		COVER
6	1	664 728 680		SCHRAUBE		SCREW
7	1	664 728 450		SCHRAUBE		SCREW
8	4	664 167 700		DISTANZRING		SPACER
9	1	664 465 602		MESSERHALTER		HUB
10	1	664 004 117		MESSER	37 CM	BLADE
11	1	664 004 352		MESSERSCHRAUBE		SCREW
12	4	664 785 087		HÖHENVERSTELLUNG		SUPPORT, WHEELS
13	2	664 686 083		RAD VORNE	Ø 130	WHEEL
14	2	664 004 322		RADKAPPE VORN ROT		HUB CAP RED
14A	2	664 004 323		RADKAPPE HINTEN ROT		HUB CAP RED
15	2	664 686 085		RAD HINTEN	Ø 160	WHEEL
16	2	664 728 450		SCHRAUBE		SCREW
17	1	664 600 056		PRALLBLECH		STONE-GUARD
18	1	664 512 601		BOLZEN		PIN
19	1	664 450 250		FEDER		SPRING
20	1	664 006 940		HOLM, LINKS UNTERTEIL		HANDLE, L LOWER PART
21	1	664 006 939		HOLM, RECHTS UNTERTEIL		HANDLE, R LOWER PART
22	2	664 819 120		SCHRAUBE		SCREW
23	2	664 680 006		SCHEIBE		WASHER
24	2	664 399 900		GRIFF		KNOB
25	2	664 293 200		MUTTER		NUT
26	1	664 006 941		HOLM, OBERTEIL		HANDLE, UPPER PART
27	2	664 566 112		GUMMISTOPFEN		CAP
28	1	664 192 151		KABELBEFESTIGUNG		FAIRLEAD
29	1	664 192 000		BOWDENZUGHALTER		ANCHOR CLAMP
30	1	664 195 101		KABELBEFESTIGUNG		FAIRLEAD
31	1	664 710 561		TOT MANNSCHALTER	7A	DEAD HAND SWITCH
32	1	664 540 260		FEDERING		GROWER
33	1	664 293 200		MUTTER		NUT
34	1	664 110 275		GUMMISTOPFEN		CAP
41	1	664 390 000		KORB, KOMPLETT		GRASSCATCHER, COMPLETE
42	2	664 486 049		KORB, OBER/UNTERTEIL		GRASS-BOX, UPPER/LOWER PART
•	1	664 008 592		SATZ, SCHRAUBEN ZUR BEFESTIGUNG VON OBERHOLM UND UNTERHOLM		OUTFIT, SCREWS

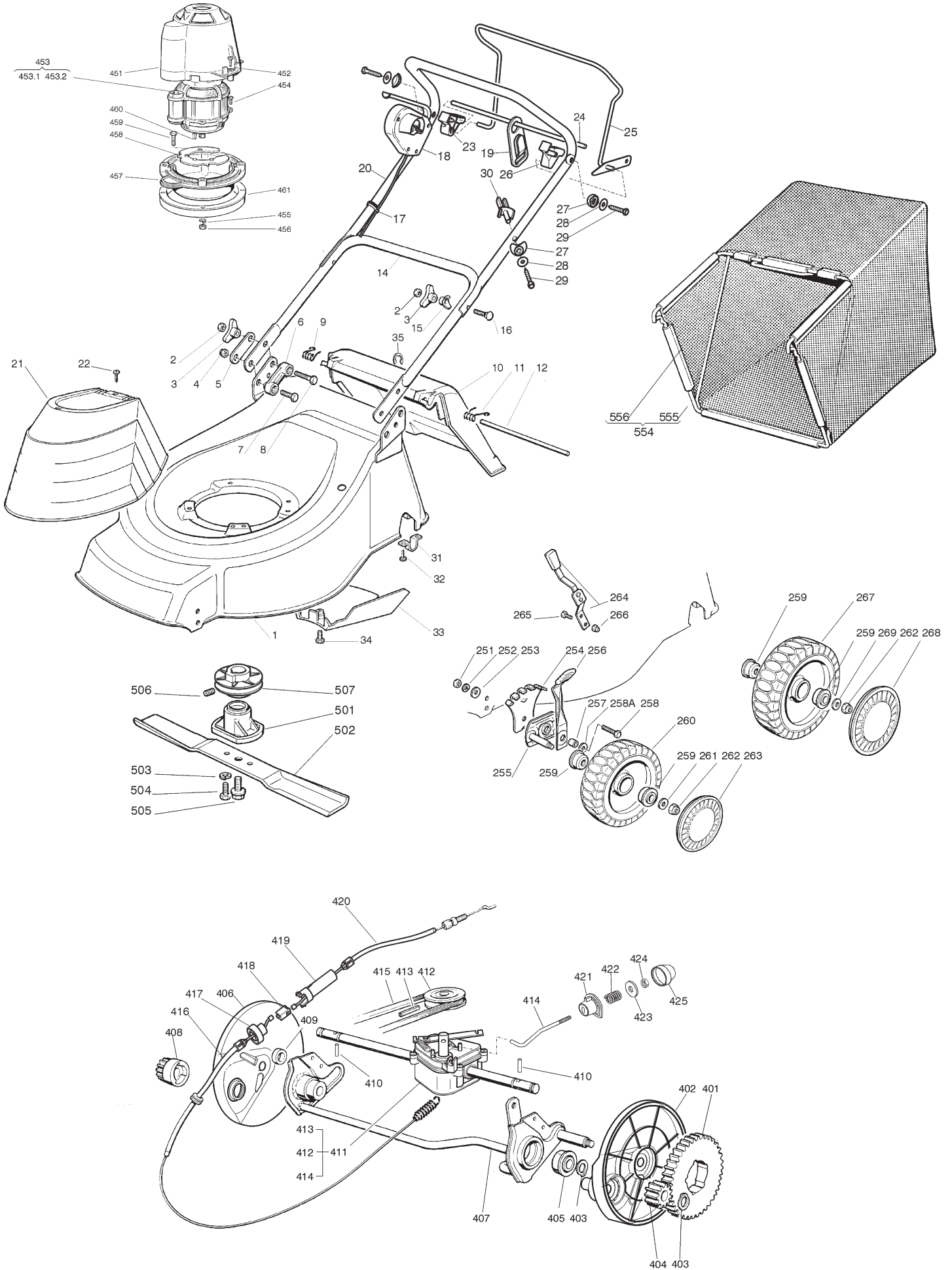

**3****EM-4316 S****DOLMAR**

Pos.	EM-4316 S	Teil-Nr. PartNo.	Hinweise Notes	Bezeichnung	Spezifikation Specification	Description
1	1	664 002 363		GEHÄUSE ROT		DECK RED
2	4	664 293 200		MUTTER		NUT
3	4	664 399 900		GRIFF		KNOB
4	2	664 155 000		MUTTER		NUT
5	2	664 551 574		PLATTE, ÄUßERE		PLATE, OUTSIDE
6	2	664 551 575		PLATTE, INNERE		PLATE, INSIDE
7	2	664 793 300		SCHRAUBE		SCREW
8	2	664 691 115		SCHRAUBE		SCREW
9	1	664 450 410		FEDER RECHTE		RIGHT SPRING
10	1	664 600 046		PRALLBLECH		STONE-GUARD
11	1	664 450 420		FEDER LINKE		LEFT SPRING
12	1	664 517 906		BOLZEN		PIN
14	1	664 006 512		HOLM, UNTERTEIL		HANDLE, LOWER PART
15	2	664 680 006		SCHEIBE		WASHER
16	2	664 819 201		SCHRAUBE		SCREW
17	2	664 192 000		BOWDENZUGHALTER		ANCHOR CLAMP
18	1	664 710 604		TOT MANNSCHALTER	10A	DEAD HAND SWITCH
19	1	664 195 101		KABELBEFESTIGUNG		FAIRLEAD
20	1	664 006 957		HOLM, OBERTEIL		HANDLE, UPPER PART
21	1	664 055 033		HAUBE		COVER
22	2	664 728 680		SCHRAUBE		SCREW
23	1	664 806 518		HALTER, RECHTER		SUPPORT, RIGHT
24	1	664 020 320		KABELHALTER		FAIRLEAD BEARING
25	1	664 001 245		ANTRIEB HEBEL		DRIVING LEVER
26	1	664 806 519		HALTER, LINKER		SUPPORT, LEFT
27	3	664 680 007		SCHEIBE		WASHER
28	3	664 523 040		SCHEIBE		WASHER
29	3	664 735 103		SCHRAUBE		SCREW
30	1	664 806 520		HALTER, REGLER		SUPPORT, ADJUSTER
31	2	664 545 152		PLATTE		PLATE
32	4	664 788 910		SCHRAUBE		SCREW
33	1	664 060 191		SCHUTZ, RIEMEN		PROTECTION, BELT
34	1	664 727 791		SCHRAUBE		SCREW
35	1	664 000 930		SPRENGRING		SNAP RING
251	2	664 293 200		MUTTER		NUT
252	2	664 583 500		FEDERRING		GROWER
253	2	664 523 070		SCHEIBE		WASHER
254	2	664 735 547		SEKTOR, HÖHENVERSTELLUNG		SECTOR, HEIGHT ADJUSTMENT
255	2	664 005 082		HALTER, RAD		SUPPORT, WHEEL
256	2	664 003 285		HEBEL, HÖHENVERSTELLUNG		LEVER, HEIGHT ADJUSTMENT
257	2	664 171 001		DISTANZRING		SPACER
258	2	664 793 701		SCHRAUBE		SCREW
258A	2	664 521 350		SCHEIBE		WASHER
259	8	664 122 200		LAGER		BEARING
260	2	664 007 336		RAD MIT STOLLENPROFIL	Ø 170	WHEEL, KNOBBLY
261	2	664 521 350		SCHEIBE		WASHER
262	4	664 155 000		MUTTER		NUT
263	2	664 110 304		RADKAPPE VORN ROT		HUB CAP RED
264	1	664 003 279		HÖHENVERSTELLUNG		LEVER, HEIGHT ADJUSTMENT
265	2	664 789 000		SCHRAUBE		SCREW
266	2	664 154 330		MUTTER		NUT
267	2	664 007 337		RAD MIT STOLLENPROFIL	Ø 210	WHEEL, KNOBBLY
268	2	664 110 305		RADKAPPE HINTEN ROT		HUB CAP RED
269	2	664 369 500		SCHEIBE		WASHER
401	2	664 120 105		KRANZ		RING GEAR COURONNE
402	1	664 600 093		SCHUTZ, LINKS RÄDER		PROTECTION, LEFT WHEEL
403	4	664 608 600		SEEGER		SEEGER
404	1	664 570 120		RITZEL LINKS		PINION LEFT
405	2	664 216 035		LAGER		BEARING
406	1	664 600 092		SCHUTZ, RECHTS RÄDER		PROTECTION, RIGHT WHEEL
407	1	664 000 147		ACHSE, HINTERRAD		AXLE, REAR WHEELS
408	1	664 570 110		RITZEL RECHTS		PINION RIGHT
409	1	664 170 800		DISTANZRING		SPACER
410	2	664 753 000		STIFT		PIN
411	1	664 003 059		ANTRIEB		GEAR BOX
412	1	664 601 904		RIEMENSCHLEIBE		PULLEY
413	1	664 645 705		STIFT		PIN
414	1	664 033 280		VERSTELLUNGSSTANGE		ADJUSTMENT ROD
415	1	664 063 710		RIEMEN	Z 25	BELT
416	1	664 001 138		KABEL, ANTRIEB UNTER		CABLE, REAR DRIVE LOWER
416.1	1	664 564 510		KABELDURCHGANG		FAIRLEAD
417	1	664 246 031		VERBINDUNG OBEN		LOWER JOINT

**3****EM-4316 S****DOLMAR**

Pos.	EM-4316 S	Teil-Nr. PartNo.	Hinweise Notes	Bezeichnung	Spezifikation Specification	Description
418	1	664 042 040		ISOLATION KOMPASS		ISOLATION COMPASS
419	1	664 246 030		VERBINDUNG UNTEN		UPPER JOINT
420	1	664 001 150		KABEL, ANTRIEB OBER		CABLE, REAR DRIVE UPPER
421	1	664 041 957		BUCHSE		BUSH
422	1	664 450 063		FEDER		SPRING
423	1	664 680 009		SCHEIBE		WASHER
424	1	664 154 510		MUTTER		NUT
425	1	664 110 230		GUMMISTOPFEN		CAP
451	1	664 785 061		HALTER, HAUBE		SUPPORT, COVER
452	4	664 728 710		SCHRAUBE		SCREW
453	1	664 563 009		MOTOR RST	1600W (230V)	MOTOR RST
453.1	1	664 740 051		LÜFTER	RST MOTOR	FAN
453.2	1	664 222 038		KONDENSATOR	20 µF (RST)	CONDENSER
454	4	664 735 410		SCHRAUBE		SCREW
455	4	664 583 500		FEDERRING		GROWER
456	4	664 293 200		MUTTER		NUT
457	1	664 207 211		FLANSCH		FLANGE
458	1	664 720 360		LÜFTUNGSSCHIRM		VENTILATION SCREEN
459	4	664 691 800		SCHRAUBE	M8X60	SCREW
460	1	664 139 440		KEIL		FEATHER
461	1	664 003 471		DISTANZRING		SPACER
501	1	664 463 186		MESSERHALTER		HUB
502	1	664 531 043		MESSER STANDARD	43 CM	BLADE STANDARD
503	2	664 583 500		FEDERRING		GROWER
504	2	664 793 101		SCHRAUBE		SCREW
505	1	664 004 352		MESSERSCHRAUBE		SCREW
506	1	664 713 801		STIFT		PIN
507	1	664 601 911		RIEMENSCHLEIFE		PULLEY
554	1	664 002 207		SACK, KOMPLETT	DOLMAR	GRASSCATCHER, CANVASS COMPLETE
555	1	664 006 418		RAHMEN SACK		CHASSIS BOX
556	1	664 002 105		SACK, TUCH	OHNE AUFDRUCK	BOX, FABRIC
•	1	664 008 596		SATZ, SCHRAUBEN ZUR BEFESTIGUNG VON OBERHOLM UND UNTERHOLM		OUTFIT, SCREWS





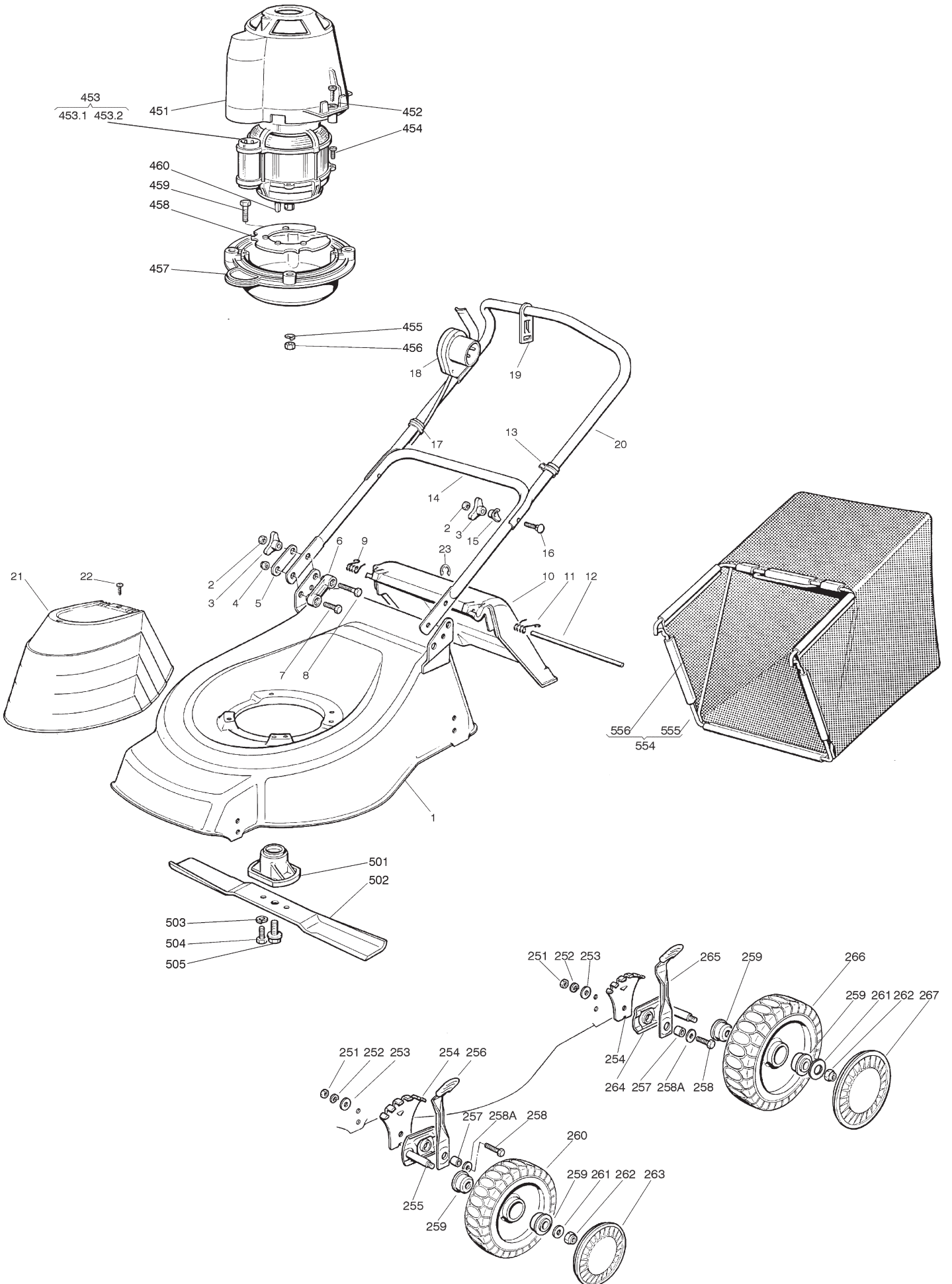

4

EM-4816

DOLMAR



Pos.	EM-4816	Teil-Nr. PartNo.	Hinweise Notes	Bezeichnung	Spezifikation Specification	Description
1	1	664 002 364		GEHÄUSE ROT		DECK RED
2	4	664 293 200		MUTTER		NUT
3	4	664 399 900		GRIFF		KNOB
4	2	664 155 000		MUTTER		NUT
5	2	664 551 574		PLATTE, ÄUßERE		PLATE, OUTSIDE
6	2	664 551 575		PLATTE, INNERE		PLATE, INSIDE
7	2	664 793 300		SCHRAUBE		SCREW
8	2	664 691 115		SCHRAUBE		SCREW
9	1	664 450 410		FEDER RECHTE		RIGHT SPRING
10	1	664 600 046		PRALLBLECH		STONE-GUARD
11	1	664 450 420		FEDER LINKE		LEFT SPRING
12	1	664 517 906		BOLZEN		PIN
13	1	664 192 151		KABELBEFESTIGUNG		FAIRLEAD
14	1	664 006 512		HOLM, UNTERTEIL		HANDLE, LOWER PART
15	2	664 680 006		SCHEIBE		WASHER
16	2	664 819 201		SCHRAUBE		SCREW
17	1	664 192 000		BOWDENZUGHALTER		ANCHOR CLAMP
18	1	664 710 604		TOT MANNSCHALTER	10A	DEAD HAND SWITCH
19	1	664 195 101		KABELBEFESTIGUNG		FAIRLEAD
20	1	664 007 017		HOLM, OBERTEIL		HANDLE, UPPER PART
21	1	664 055 033		HAUBE		COVER
22	2	664 728 680		SCHRAUBE		SCREW
23	1	664 000 930		SPRENGRING		SNAP RING
251	4	664 293 200		MUTTER		NUT
252	4	664 583 500		FEDERRING		GROWER
253	4	664 523 070		SCHEIBE		WASHER
254	4	664 735 547		SEKTOR, HÖHENVERSTELLUNG		SECTOR, HEIGHT ADJUSTMENT
255	2	664 005 082		HALTER, RAD		SUPPORT, WHEEL
256	2	664 003 285		HEBEL, HÖHENVERSTELLUNG		LEVER, HEIGHT ADJUSTMENT
257	4	664 171 001		DISTANZRING		SPACER
258	4	664 793 701		SCHRAUBE		SCREW
258A	4	664 521 350		SCHEIBE		WASHER
259	8	664 034 508		BUCHSE		BUSH
260	2	664 007 336		RAD MIT STOLLENPROFIL	Ø 170	WHEEL, KNOBBLY
261	4	664 523 060		SCHEIBE		WASHER
262	4	664 155 000		MUTTER		NUT
263	2	664 110 304		RADKAPPE VORN ROT		HUB CAP RED
264	2	664 005 084		HALTER, RAD		SUPPORT, WHEEL
265	2	664 003 286		HEBEL, HÖHENVERSTELLUNG		LEVER, HEIGHT ADJUSTMENT
266	2	664 007 337		RAD MIT STOLLENPROFIL HINTEN	Ø 210	WHEEL, KNOBBLY
267	2	664 110 305		RADKAPPE HINTEN ROT		HUB CAP RED
451	1	664 785 061		HALTER, HAUBE		SUPPORT, COVER
452	4	664 728 710		SCHRAUBE		SCREW
453	1	664 563 009		MOTOR RST	1600W (230V)	MOTOR RST
453.1	1	664 740 051		LÜFTER	RST MOTOR	FAN
453.2	1	664 222 038		KONDENSATOR	20 µF (RST)	CONDENSER
454	4	664 735 410		SCHRAUBE		SCREW
455	4	664 583 500		FEDERRING		GROWER
456	4	664 293 200		MUTTER		NUT
457	1	664 207 211		FLANSCH		FLANGE
458	1	664 720 360		LÜFTUNGSSCHIRM		VENTILATION SCREEN
459	4	664 793 700		SCHRAUBE	M8x30	SCREW
460	1	664 139 440		KEIL		FEATHER
501	1	664 463 186		MESSERHALTER		HUB
502	1	664 531 048		MESSER STANDARD	48 CM	BLADE STANDARD
503	2	664 583 500		FEDERRING		GROWER
504	2	664 793 101		SCHRAUBE		SCREW
505	1	664 004 352		MESSERSCHRAUBE		SCREW
554	1	664 002 207		SACK, KOMPLETT	DOLMAR	GRASSCATCHER, CANVASS COMPLETE
555	1	664 006 418		RAHMEN SACK		CHASSIS BOX
556	1	664 002 105		SACK, TUCH	OHNE AUFDRUCK	BOX, FABRIC
•	1	664 008 596		SATZ, SCHRAUBEN ZUR BEFESTIGUNG VON OBERHOLM UND UNTERHOLM		OUTFIT, SCREWS

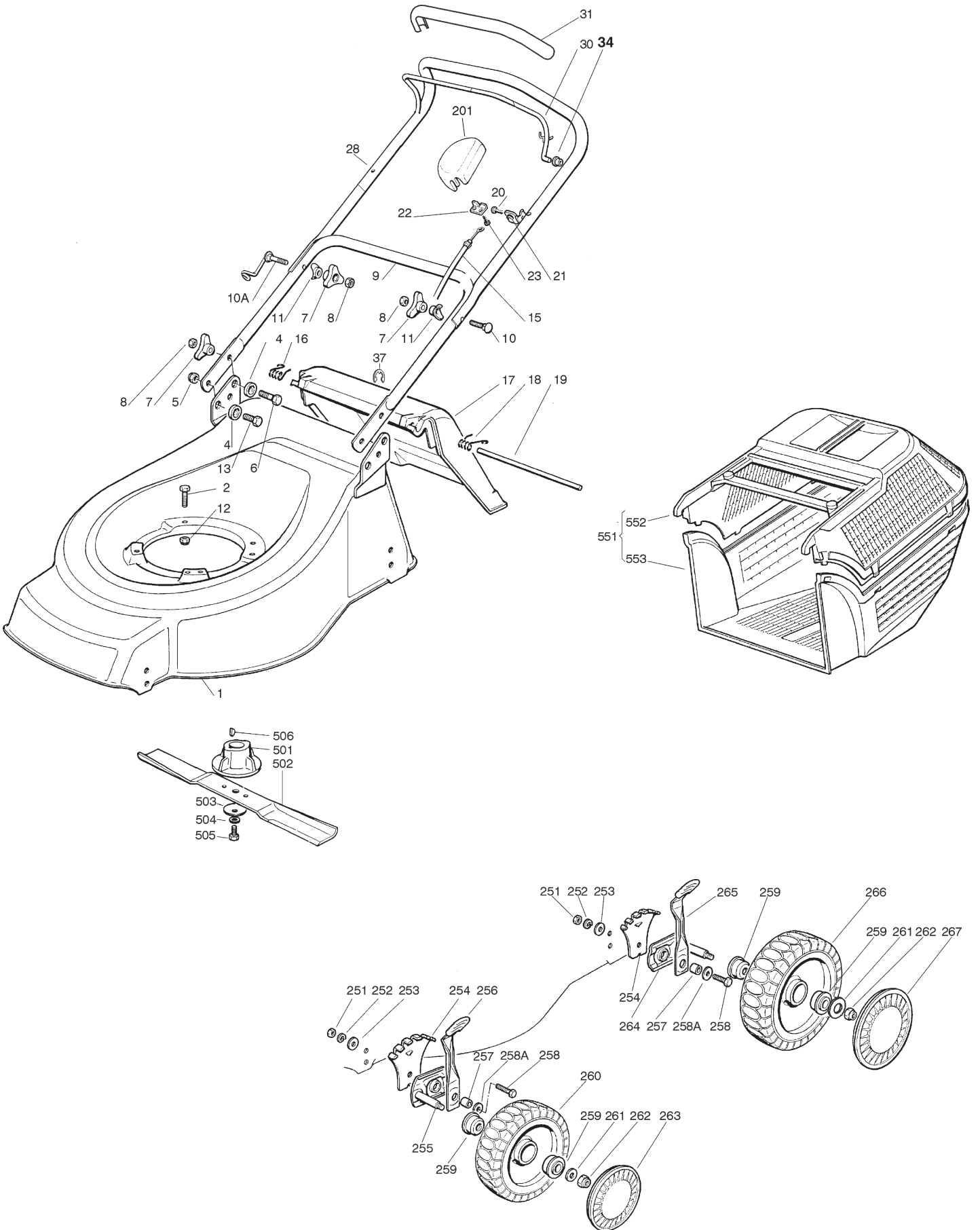

5

PM-43

**DOLMAR**  

Pos.	PM-43	Teil-Nr. PartNo.	Hinweise Notes	Bezeichnung	Spezifikation Specification	Description
1	1	664 002 362		GEHÄUSE ROT		DECK RED
2	1	664 691 800		SCHRAUBE		SCREW
2	2	664 793 700		SCHRAUBE		SCREW
4	4	664 041 955		BUCHSE		BUSH
5	2	664 155 000		MUTTER		NUT
6	2	664 793 700		SCHRAUBE		SCREW
7	4	664 399 900		GRIFF		KNOB
8	4	664 293 200		MUTTER		NUT
9	1	664 006 512		HOLM, UNTERTEIL		HANDLE, LOWER PART
10	1	664 819 201		SCHRAUBE		SCREW
10A	1	664 003 801		FEDER		SPRING
11	2	664 680 006		SCHEIBE		WASHER
12	1	664 155 000		MUTTER		NUT
12	2	664 293 201		MUTTER		NUT
13	2	664 792 610		SCHRAUBE		SCREW
15	1	664 000 633		KABEL, MOTORBREMSE	B&S	CABLE, THREAD MOTOR BRAKE
16	1	664 450 410		RECHTE FEDER		R SPRING
17	1	664 600 046		PRALLBLECH		STONE-GUARD
18	1	664 450 420		LINKE FEDER		LEFT SPRING
19	1	664 517 906		BOLZEN		PIN
20	1	664 728 518		SCHRAUBE		SCREW
21	1	664 806 612		HALTER		SUPPORT
22	1	664 981 467		PLATTE		PLATE
23	2	664 735 105		SCHRAUBE		SCREW
28	1	664 007 018		HOLM, OBERTEIL		HANDLE, UPPER PART
30	1	664 003 291		HEBEL, MOTORBREMSE		LEVER, MOTOR BRAKE
31	1	664 291 050		HANDGRIFF SCHWARZ		HANDGRIP BLACK
34	2	664 041 966		BUCHSE		BUSH
37	1	664 000 930		SPRENGRING		SNAP RING
201	1	664 601 000		SCHUTZ		PROTECTION
251	4	664 293 200		MUTTER		NUT
252	4	664 583 500		FEDERRING		GROWER
253	4	664 523 070		SCHEIBE		WASHER
254	4	664 735 547		SEKTOR, HÖHENVERSTELLUNG		SECTOR, HEIGHT ADJUSTMENT
255	2	664 005 082		HALTER, RAD		SUPPORT, WHEEL
256	2	664 003 285		HEBEL, HÖHENVERSTELLUNG		LEVER, HEIGHT ADJUSTMENT
257	4	664 171 001		DISTANZRING		SPACER
258	4	664 793 701		SCHRAUBE		SCREW
258A	4	664 521 350		SCHEIBE		WASHER
259	8	664 034 508		BUCHSE		BUSH
260	2	664 007 336		RAD MIT STOLLENPROFIL	Ø 170	WHEEL, KNOBBLY
261	4	664 523 060		SCHEIBE		WASHER
262	4	664 155 000		MUTTER		NUT
263	2	664 110 304		RADKAPPE VORN ROT		HUB CAP RED
264	2	664 005 084		HALTER, RAD		SUPPORT, WHEEL
265	2	664 003 286		HEBEL, HÖHENVERSTELLUNG		LEVER, HEIGHT ADJUSTMENT
266	2	664 007 337		RAD MIT STOLLENPROFIL HINTEN	Ø 210	WHEEL, KNOBBLY
267	2	664 110 305		RADKAPPE HINTEN ROT		HUB CAP RED
501	1	664 463 012		MESSERHALTER		HUB
502	1	664 531 043		MESSER STANDARD	43 CM	BLADE STANDARD
503	1	664 160 400		FEDERSCHEIBE		SPRING WASHER
504	1	664 523 080		SCHEIBE		WASHER
505	1	664 735 698		MESSERSCHRAUBE		SCREW
506	1	664 139 100		KEIL		FEATHER
551	1	664 004 000		KORB, KOMPLETT		GRASS-BOX, COMPLETE
552	1	664 486 073		KORB, OBERTEIL		GRASS-BOX, UPPER PART
553	1	664 486 074		KORB, UNTERTEIL		GRASS-BOX, LOWER PART
•	1	664 008 614		SATZ, SCHRAUBEN ZUR BEFESTIGUNG VON OBERHOLM UND UNTERHOLM		OUTFIT, SCREWS

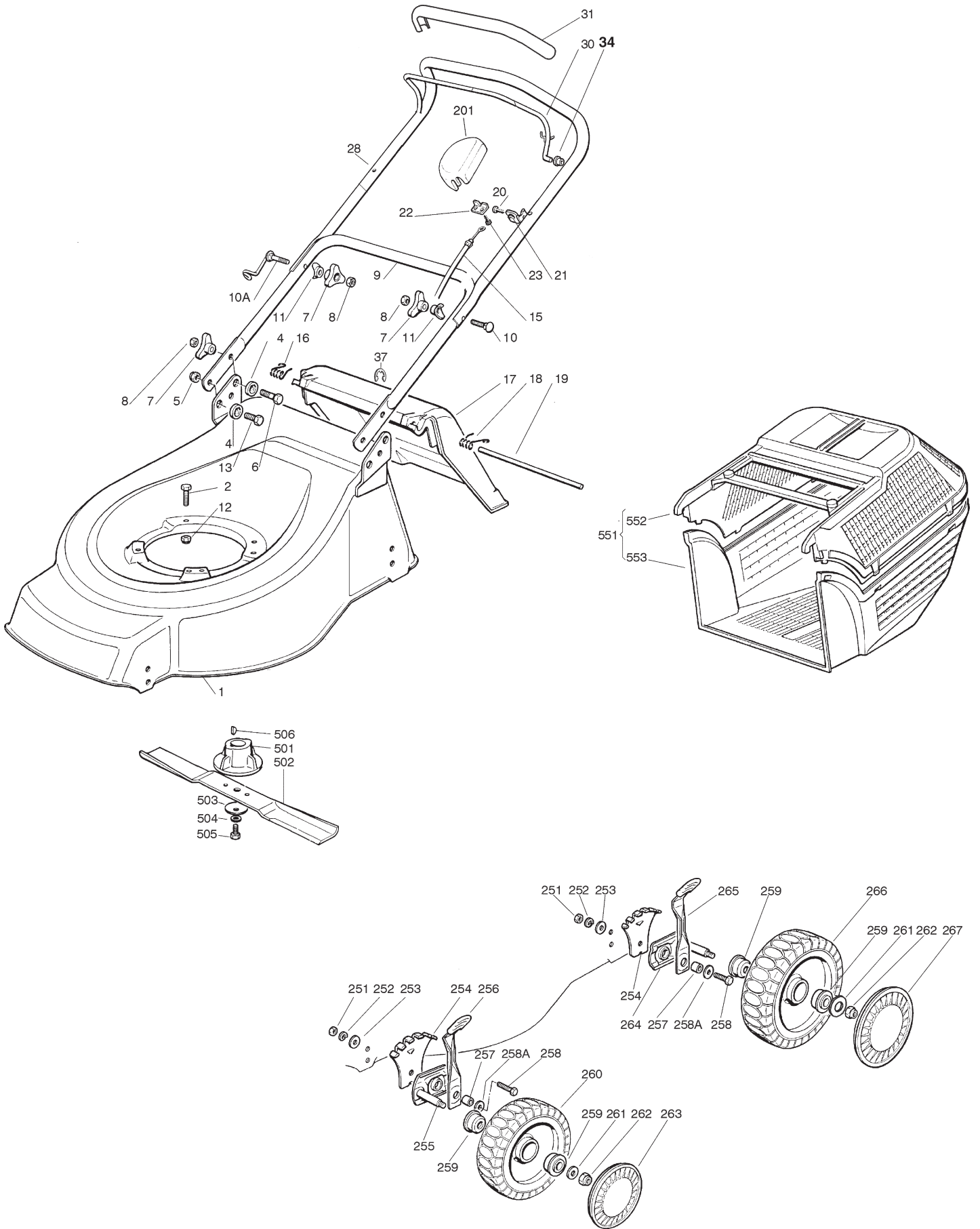

6

PM-48

DOLMAR



Pos.	PM-48	Teil-Nr. PartNo.	Hinweise Notes	Bezeichnung	Spezifikation Specification	Description
1	1	664 002 364		GEHÄUSE ROT		DECK RED
2	1	664 691 800		SCHRAUBE		SCREW
2	2	664 793 700		SCHRAUBE		SCREW
4	4	664 041 955		BUCHSE		BUSH
5	2	664 155 000		MUTTER		NUT
6	2	664 793 700		SCHRAUBE		SCREW
7	4	664 399 900		GRIFF		KNOB
8	4	664 293 200		MUTTER		NUT
9	1	664 006 512		HOLM, UNTERTEIL		HANDLE, LOWER PART
10	1	664 819 201		SCHRAUBE		SCREW
10A	1	664 003 801		FEDER		SPRING
11	2	664 680 006		SCHEIBE		WASHER
12	1	664 155 000		MUTTER		NUT
12	2	664 293 201		MUTTER		NUT
13	2	664 792 610		SCHRAUBE		SCREW
15	1	664 001 625		KABEL, MOTORBREMSE	B&S	CABLE, THREAD MOTOR BRAKE
16	1	664 450 410		RECHTE FEDER		R SPRING
17	1	664 600 046		PRALLBLECH		STONE-GUARD
18	1	664 450 420		LINKE FEDER		LEFT SPRING
19	1	664 517 906		BOLZEN		PIN
20	1	664 728 518		SCHRAUBE		SCREW
21	1	664 806 612		HALTER		SUPPORT
22	1	664 981 467		PLATTE		PLATE
23	2	664 735 105		SCHRAUBE		SCREW
28	1	664 007 018		HOLM, OBERTEIL		HANDLE, UPPER PART
30	1	664 003 291		HEBEL, MOTORBREMSE		LEVER, MOTOR BRAKE
31	1	664 291 050		HANDGRIFF SCHWARZ		HANDGRIP BLACK
34	2	664 041 966		BUCHSE		BUSH
37	1	664 000 930		SPRENGRING		SNAP RING
201	1	664 601 000		SCHUTZ		PROTECTION
251	4	664 293 200		MUTTER		NUT
252	4	664 583 500		FEDERRING		GROWER
253	4	664 523 070		SCHEIBE		WASHER
254	4	664 735 547		SEKTOR, HÖHENVERSTELLUNG		SECTOR, HEIGHT ADJUSTMENT
255	2	664 005 082		HALTER, RAD		SUPPORT, WHEEL
256	2	664 003 285		HEBEL, HÖHENVERSTELLUNG		LEVER, HEIGHT ADJUSTMENT
257	4	664 171 001		DISTANZRING		SPACER
258	4	664 793 701		SCHRAUBE		SCREW
258A	4	664 521 350		SCHEIBE		WASHER
259	8	664 034 508		BUCHSE		BUSH
260	2	664 007 336		RAD MIT STOLLENPROFIL	Ø 170	WHEEL, KNOBBLY
261	4	664 523 060		SCHEIBE		WASHER
262	4	664 155 000		MUTTER		NUT
263	2	664 110 304		RADKAPPE VORN ROT		HUB CAP RED
264	2	664 005 084		HALTER, RAD		SUPPORT, WHEEL
265	2	664 003 286		HEBEL, HÖHENVERSTELLUNG		LEVER, HEIGHT ADJUSTMENT
266	2	664 007 337		RAD MIT STOLLENPROFIL HINTEN	Ø 210	WHEEL, KNOBBLY
267	2	664 110 305		RADKAPPE HINTEN ROT		HUB CAP RED
501	1	664 463 012		MESSERHALTER		HUB
502	1	664 531 048		MESSER STANDARD	48 CM	BLADE STANDARD
503	1	664 160 400		FEDERSCHEIBE		SPRING WASHER
504	1	664 523 080		SCHEIBE		WASHER
505	1	664 735 698		MESSERSCHRAUBE		SCREW
506	1	664 139 100		KEIL		FEATHER
551	1	664 004 000		KORB, KOMPLETT		GRASS-BOX, COMPLETE
552	1	664 486 073		KORB, OBERTEIL		GRASS-BOX, UPPER PART
553	1	664 486 074		KORB, UNTERTEIL		GRASS-BOX, LOWER PART
•	1	664 008 614		SATZ, SCHRAUBEN ZUR BEFESTIGUNG VON OBERHOLM UND UNTERHOLM		OUTFIT, SCREWS

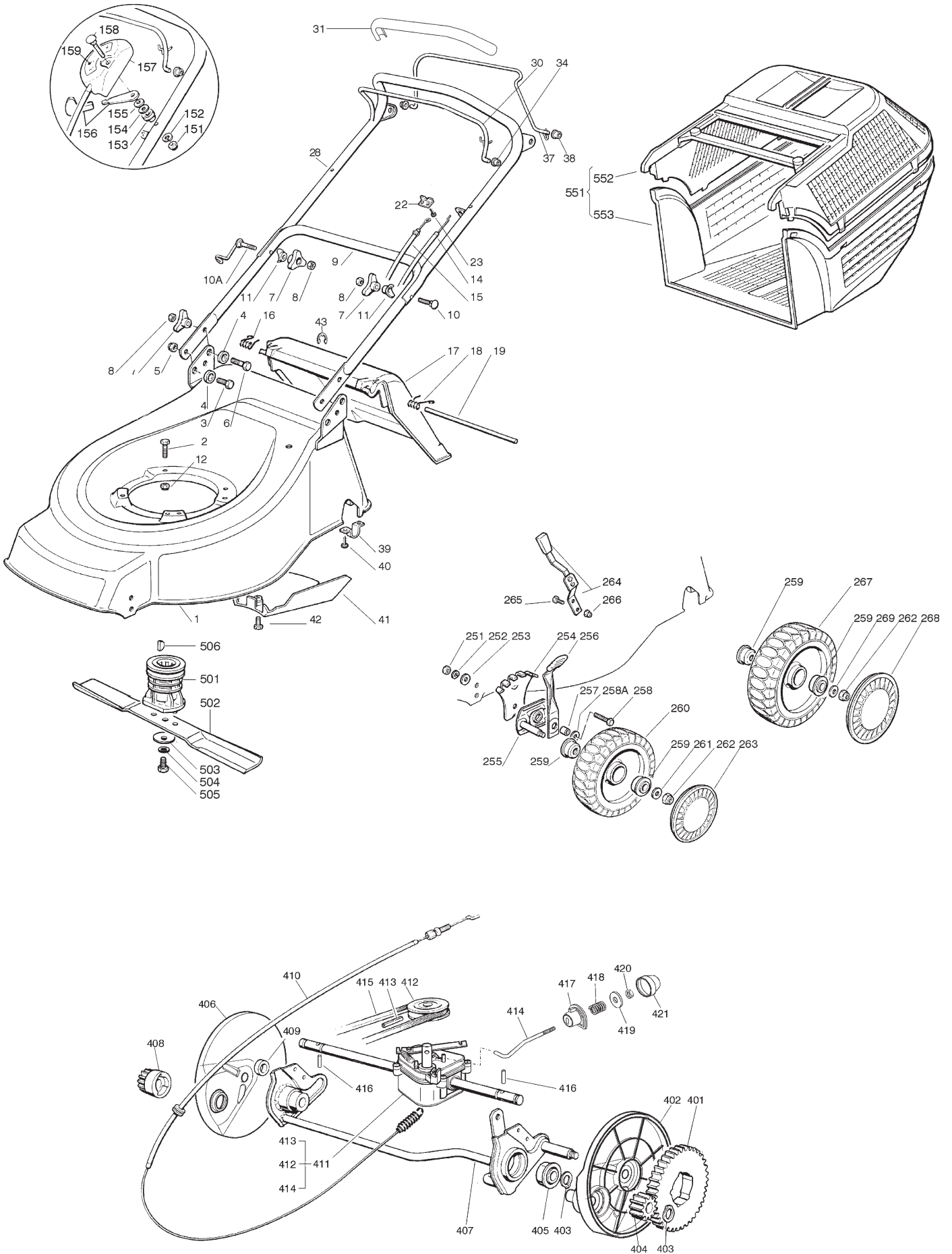



7

PM-48 S

**DOLMAR**  

Pos.	PM-48 S	Teil-Nr. PartNo.	Hinweise Notes	Bezeichnung	Spezifikation Specification	Description
1	1	664 002 365		GEHÄUSE ROT		DECK RED
2	1	664 691 800		SCHRAUBE		SCREW
2	2	664 793 700		SCHRAUBE		SCREW
3	2	664 792 610		SCHRAUBE		SCREW
4	4	664 041 955		BUCHSE		BUSH
5	2	664 155 000		MUTTER		NUT
6	2	664 793 700		SCHRAUBE		SCREW
7	4	664 399 900		GRIFF		KNOB
8	4	664 293 200		MUTTER		NUT
9	1	664 006 512		HOLM, UNTERTEIL		HANDLE, LOWER PART
10	1	664 819 201		SCHRAUBE		SCREW
10A	1	664 003 801		FEDER		SPRING
11	2	664 680 006		SCHEIBE		WASHER
12	1	664 155 000		MUTTER		NUT
12	2	664 293 201		MUTTER		NUT
14	1	664 007 160		KABEL, BESCHLEUNIGER		CABLE, THROTTLE
15	1	664 000 631		KABEL, MOTORBREMSE	B&S	CABLE, THREAD MOTOR BRAKE
16	1	664 450 410		RECHTE FEDER		R SPRING
17	1	664 600 046		PRALLBLECH		STONE-GUARD
18	1	664 450 420		LINKE FEDER		LEFT SPRING
19	1	664 517 906		BOLZEN		PIN
22	1	664 981 467		PLATTE		PLATE
23	2	664 735 105		SCHRAUBE		SCREW
28	1	664 007 024		HOLM, OBERTEIL		HANDLE, UPPER PART
30	1	664 003 291		HEBEL, MOTORBREMSE		LEVER, MOTOR BRAKE
31	1	664 291 050		HANDGRIFF SCHWARZ		HANDGRIP BLACK
34	1	664 041 966		BUCHSE		BUSH
37	1	664 003 288		HEBEL, ANTRIEB		LEVER, DRIVING
38	2	664 041 965		BUCHSE		BUSH
39	2	664 545 152		PLATTE		PLATE
40	4	664 731 350		SCHRAUBE		SCREW
41	1	664 060 192		SCHUTZ, RIEMEN		PROTECTION, BELT
42	1	664 727 791		SCHRAUBE		SCREW
43	1	664 000 930		SPRENGRING		SNAP RING
151	1	664 291 000		MUTTER		NUT
152	1	664 581 500		FEDERRING		GROWER
153	1	664 171 005		DISTANZRING		SPACER
154	1	664 521 360		SCHEIBE		WASHER
155	1	664 508 100		FEDERSCHEIBE		SPRING WASHER
156	1	664 007 279		HEBEL, BESCHLEUNIGER		LEVER, THROTTLE
157	1	664 007 080		MOTORFERNBEDIENUNG		CABLE, THROTTLE
158	1	664 815 000		SCHRAUBE		SCREW
159	1	664 356 703		ETIKETTE	B&S	LABEL
251	2	664 293 200		MUTTER		NUT
252	2	664 583 500		FEDERRING		GROWER
253	2	664 523 070		SCHEIBE		WASHER
254	2	664 735 547		SEKTOR, HÖHENVERSTELLUNG		SECTOR, HEIGHT ADJUSTMENT
255	2	664 005 082		HALTER, RAD		SUPPORT, WHEEL
256	2	664 003 285		HEBEL, HÖHENVERSTELLUNG		LEVER, HEIGHT ADJUSTMENT
257	2	664 171 001		DISTANZRING		SPACER
258	2	664 793 701		SCHRAUBE		SCREW
258A	2	664 521 350		SCHEIBE		WASHER
259	8	664 122 200		LAGER		BEARING
260	2	664 007 336		RAD MIT STOLLENPROFIL	Ø 170	WHEEL, KNOBBLY
261	2	664 521 350		SCHEIBE		WASHER
262	4	664 155 000		MUTTER		NUT
263	2	664 110 304		RADKAPPE VORN ROT		HUB CAP RED
264	1	664 003 279		HÖHENVERSTELLUNG		LEVER, HEIGHT ADJUSTMENT
265	2	664 789 000		SCHRAUBE		SCREW
266	2	664 154 330		MUTTER		NUT
267	2	664 007 337		RAD MIT STOLLENPROFIL	Ø 210	WHEEL, KNOBBLY
268	2	664 110 305		RADKAPPE HINTEN ROT		HUB CAP RED
269	2	664 369 500		SCHEIBE		WASHER
401	2	664 120 105		KRANZ		RING GEAR COURONNE
402	1	664 600 093		SCHUTZ, LINKS RÄDER		PROTECTION, LEFT WHEEL
403	4	664 608 600		SEEGER		SEEGER
404	1	664 570 120		RITZEL LINKS		PINION LEFT
405	2	664 216 035		LAGER		BEARING
406	1	664 600 092		SCHUTZ, RECHTS RÄDER		PROTECTION, RIGHT WHEEL
407	1	664 000 147		ACHSE, HINTERRAD		AXLE, REAR WHEELS
408	1	664 570 110		RITZEL RECHTS		PINION RIGHT
409	1	664 170 800		DISTANZRING		SPACER
410	1	664 001 143		KABEL, RADANTRIEB		CABLE, REAR DRIVE

**7****PM-48 S****DOLMAR**  

Pos.	PM-48 S	Teil-Nr. PartNo.	Hinweise Notes	Bezeichnung	Spezifikation Specification	Description
411	1	664 003 059		ANTRIEB		GEAR BOX
412	1	664 601 904		RIEMENSCHLEIBE		PULLEY
413	1	664 645 705		STIFT		PIN
414	1	664 033 280		VERSTELLUNGSSTANGE		ADJUSTMENT ROD
415	1	664 063 800		RIEMEN	Z 27	BELT
416	2	664 753 000		STIFT		PIN
417	1	664 041 957		BUCHSE		BUSH
418	1	664 450 063		FEDER		SPRING
419	1	664 680 009		SCHEIBE		WASHER
420	1	664 154 510		MUTTER		NUT
421	1	664 110 230		GUMMISTOPFEN		CAP
501	1	664 465 607		NABE MIT SCHEIBE		HUB WITH PULLEY
502	1	664 531 048		MESSER STANDARD	48 CM	BLADE STANDARD
503	1	664 160 400		FEDERSCHLEIBE		SPRING WASHER
504	1	664 523 080		SCHEIBE		WASHER
505	1	664 735 698		MESSERSCHRAUBE		SCREW
506	1	664 139 100		KEIL		FEATHER
551	1	664 004 000		KORB, KOMPLETT		GRASS-BOX, COMPLETE
552	1	664 486 073		KORB, OBERTEIL		GRASS-BOX, UPPER PART
553	1	664 486 074		KORB, UNTERTEIL		GRASS-BOX, LOWER PART
•	1	664 008 614		SATZ, SCHRAUBEN ZUR BEFESTIGUNG VON OBERHOLM UND UNTERHOLM		OUTFIT, SCREWS



<b>1</b>	<b>EM-3310</b>
<b>2</b>	<b>EM-3713</b>
<b>3</b>	<b>EM-4316 S</b>
<b>4</b>	<b>EM-4816</b>
<b>5</b>	<b>PM-43</b>
<b>6</b>	<b>PM-48</b>
<b>7</b>	<b>PM-48 S</b>

	<b>Zeichenerklärung</b>	<b>Key to symbols</b>	<b>Légende</b>
<p>⇒ 1999999 2000000 ⇒ 4/95 ⇒ SI 5/95 =&gt; Acc. = { m* ⊛ Corr.</p>	<p>Produktion bis Serien-Nr. Neues Teil ab Serien-Nr. Neues Teil ab Monat / Jahr Siehe Service-Information Monat / Jahr Teil gleichwertig ersetzt Zubehör (nicht im Lieferumfang) Keine Serienausführung, jedoch verwendbar Beinhaltet Positions-Nr. Meterware Innensternschraube Druckfehlerberichtigung</p>	<p>Production to serial number New part from serial number New part from Month / Year See Service-Information Month / Year Modified part Accessories (not included in the delivery inventory) No standard execution, may be used Contains item no. Sold by the meter Star socket screw Error correction</p>	<p>Production jusqu'à n° de série Nouveau pièce à partir du n° de série Nouveau pièce à partir de Mois / Année Voir Service-Information Mois / Année Pièce modifiée Accessoires (non compris dans la livraison) Aucune exécut. en série, cependant utilisable contient n° de numéro Au mètre Vis à étoile intérieure Rectification d'erreurs</p>
	<b>Explicación de símbolos</b>	<b>Verklaring der tekens</b>	<b>Chiarificazione dei simboli</b>
<p>⇒ 1999999 2000000 ⇒ 4/95 ⇒ SI 5/95 =&gt; Acc. = { m* ⊛ Corr.</p>	<p>Producción hasta N° de serie Pieza nueva a partir de N° de serie Pieza nueva a partir de mes / año Véase inform. servicio mes / año Pieza modificada Accesorios (no incluido en la extensión del suministro) No es de serie, pero sirve Contiene pos N° Por metro Tornillo estrella interior Fe de erratas</p>	<p>In productie tot serie-Nr. Nieuw onderdeel vanaf serie-Nr. Nieuw onderdeel vanaf maand / jaar Zie service-informatie maand / jaar Vervangen door gelijkwaardig onderdeel Accessoires (niet meegeleverd) Geen serieuitvoering, maar wel bruikbaar Omvat Positie-Nr. Metergoed Binnen-ster schroef Drukfoutcorrectie</p>	<p>Produzione fino al n. di serie Nuovo pezzo a partire dal n. di serie Nuovo pezzo a partire dal mese / anno Vedere il servizio inform. del mese / anno Pezzo sostituito con un pezzo equivalente Accessori (non compresi nell'insieme di fornitura) Non è un modello di serie, ma ugualm. utilizza. Comprende la posizione n. Articoli a metraggio Vite con intaglio a stella Rettifica di errori di stampa</p>
	<b>Objasnitev znakov</b>	<b>Teckenförklaring</b>	<b>Επεξήγηση συμβόλων</b>
<p>⇒ 1999999 2000000 ⇒ 4/95 ⇒ SI 5/95 =&gt; Acc. = { m* ⊛ Corr.</p>	<p>Produkcija do serijske številke Novi del od serijske štev. dalje Novi del od meseca / leta dalje Glej servisne informacije od meseca / leta Del enakovredno nadomeščen Pritikline (niso v obsegu dostave) Ni serijska izvedba, a uporabno Vsebuje pozicijsko štev. Metrsko blago Zvezdni vijak Popravek tiskovnih napak</p>	<p>Produktion t o m serienr Ny detalj fr o m serienr Ny detalj fr o m månad / år Se serviceinformation månad / år Ersatt med motsvarande detalj Tillbehör (ingår ej i leveransen) Ej serieutförande, men användbar Innehåller positionsnr Metervara Skruv med stjärnspår Korrigerig av tryckfel</p>	<p>Παραγωγή μέχρι τον αριθμό σειράς Νέο εξάρτημα από τον αριθμό σειράς Νέο εξάρτημα από το μήνα / έτος Βλέπε πληροφορίες του service το μήνα / έτος Ταυτόχρονη αντικατάσταση του εξαρτήματος Πρόσθετα εξαρτήματα (δεν ανήκουν στη συσκευασία παράδοσης) Δεν έχει εκδοθεί σε σειρά, αλλά χρησιμοποιείται Περιλαμβάνει τον αριθμό θέσης Εμπόρευμα με το μέτρο Βίδα με εσωτερική υποδοχή μορφής άστρου Διόρθωση λάθους πίεσης</p>